

LMS-Q680i

The new **RIEGL® LMS-Q680i** long-range airborne laser scanner makes use of a powerful laser source, multiple-time-around (MTA) processing, and digital full waveform analysis. This combination allows the operation at varying flight altitudes and is therefore ideally suited for aerial survey of complex terrain.

The **RIEGL LMS-Q680i** gives access to detailed target parameters by digitizing the echo signal online during data acquisition, and subsequent off-line waveform analysis. This method is especially valuable when dealing with difficult tasks, such as canopy height investigation or target classification. Multiple-time-around processing allows the utilization of target echo signals which have been detected out of the unambiguity range between two successive laser pulses. In post-processing the correct allocation of ambiguous echo ranges is accomplished by using **RIANALYZE** in combination with the associated algorithm library **RI-MTA**.

The operational parameters of the **RIEGL LMS-Q680i** can be configured to cover a wide field of applications. Comprehensive interface features support smooth integration of the instrument into a complete airborne scanning system.

The instrument makes use of the time-of-flight distance measurement principle of infrared nanosecond pulses. Fast opto-mechanical beam scanning provides absolutely linear, unidirectional and parallel scan lines. The instrument is extremely rugged, therefore ideally suited for the installation on aircraft. Also, it is compact and lightweight enough to be installed in small twin- or single-engine planes, helicopters or UAVs. The instrument needs only one power supply and GPS timing signals to provide online monitoring data while logging the precisely time-stamped and digitized echo signal data to the rugged **RIEGL Data Recorder**.

- **full waveform analysis for unlimited number of target echoes**
- **multiple-time-around processing**
- **high laser pulse repetition rate up to 400 kHz**
- **up to 266 000 measurements/sec on the ground**
- **high ranging accuracy up to 20 mm**
- **high scan speed up to 200 lines/sec**
- **wide scan field of view up to 60°**
- **parallel scan lines**
- **interface for smooth integration of GPS**

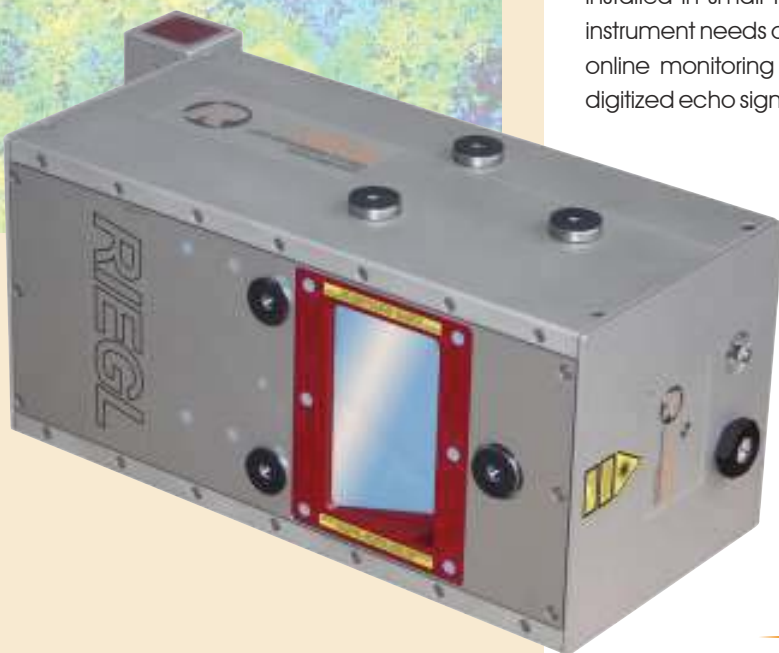

- **Topography & Mining**
- **Corridor Mapping**
- **City Modeling**
- **Mapping of Lakesides & River Banks**
- **Agriculture & Forestry**
- **Target Classification**
- **Glacier & Snowfield Mapping**
- **Power Lines**

visit our website www.riegl.com



RIEGL®
LASER MEASUREMENT SYSTEMS

Technical Data RIEGL LMS-Q680i

Laser Product Classification

Safe for the naked eye
Safe for the aided eye

Class 3R Laser Product according to IEC60825-1:2007

The following clause applies for instruments delivered into the United States: Complies with 21 CFR 1040.10 and 1040.11 except for deviations pursuant to Laser Notice No. 50, dated June 24, 2007.

> 1.5 m (NOHD)
> 10 m (ENOHD)

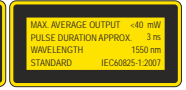

Range Measurement Performance

as a function of PRR and target reflectivity

Laser Pulse Repetition Rate	80 kHz	200 kHz	300 kHz	400 kHz
Max. Measurement Range ¹⁾ natural target $\rho \geq 20\%$ natural target $\rho \geq 60\%$	2000 m 3000 m	1350 m 2200 m	1150 m 1850 m	1000 m 1650 m
Max. Operating Flight Altitude AGL ²⁾	1600 m 5000 ft	1100 m 3600 ft	950 m 3100 ft	800 m 2600 ft

1) The following conditions are assumed:
 • target is larger than the footprint of the laser beam • average ambient brightness • visibility 23 km
 • perpendicular angle of incidence • ambiguity to be resolved by proper flight planning and multiple-time-around processing

2) Reflectivity $\rho \geq 20\%$, max. scan angle 60°, additional roll angle +/- 5°, MTA zone transitions not considered

Minimum Range

Accuracy^{3) 4)}

Precision^{3) 5)}

Laser Pulse Repetition Rate⁶⁾

Effective Measurement Rate

Laser Wavelength

Laser Beam Divergence⁷⁾

Number of Targets per Pulse

30 m
20 mm
20 mm
up to 400 000 Hz
up to 266 kHz @ 60° scan angle
near infrared
≤ 0.5 mrad
digitized waveform processing: unlimited⁸⁾
monitoring data output: first pulse

Scanner Performance

Scanning Mechanism

Scan Pattern

Scan Angle Range

Scan Speed

Angular Step Width $\Delta \theta$ ⁹⁾

between consecutive laser shots

Angle Measurement Resolution

Scan Sync

rotating polygon mirror
parallel scan lines
± 30° = 60° total
10 - 200 lines/sec
 $\Delta \theta \geq 0.002^\circ$ (for PRR 400 000 Hz⁹⁾)

0.001°
Option for synchronizing scan lines to external timing signal

3) Standard deviation one sigma @ 250 m range under RIEGL test conditions.

4) Accuracy is the degree of conformity of a measured quantity to its actual (true) value.

5) Precision, also called reproducibility or repeatability, is

the degree to which further measurements show the same result.

6) User selectable

7) 0.5 mrad correspond to 50 cm increase of beam width per 1000 m distance

8) Practically limited only by the maximum data rate allowed for the RIEGL Data Recorder

9) Minimum angle step width increasing linearly to 0.01° @ 80000 Hz laser pulse repetition rate

Intensity Measurement

For each echo signal, high-resolution 16-bit intensity information is provided which can be used for target discrimination and/or identification/classification.

Data Interfaces

Configuration

Monitoring Data Output

Digitized Data Output

GPS-System

TCP/IP Ethernet (10/100 MBit), RS232 (19.2 kBd)

TCP/IP Ethernet (10/100 MBit)

High speed serial data link to RIEGL Data Recorder

Serial RS232 interface, TTL input for 1pps synchronization pulse, accepts different data formats for GPS-time information

General Technical Data

Power Supply

Current Consumption

Main Dimensions (L x W x H)

Weight

Protection Class

Max. Flight Altitude (operating)

Max. Flight Altitude (not operating)

Temperature Range

Mounting of IMU-Sensor

18 - 32 VDC

approx. 7 A @ 24 VDC

480 x 212 x 229 mm

17.5 kg

IP54

16 500 ft (5 000 m) above MSL

18 000 ft (5 500 m) above MSL

0°C up to +40°C (operation) / -10°C up to +50°C (storage)

Steel thread inserts on the top and on the sides of the laser scanner, rigidly connected to the inner structure of the scanning mechanism

Echo Signal of the *RIEGL* LMS-Q680i

The digitization feature of the *RIEGL* LMS-Q680i enables the user to extract most comprehensive information from the echo signals. Figure 1 illustrates a measurement situation where 3 laser measurements are taken on different types of targets. The red pulses symbolize the laser signals travelling towards the target with the speed of light. When the signal interacts with the diffusely reflecting target surface, a fraction of the transmitted signal is reflected towards the laser instrument, indicated by the blue signals.

In situation 1, the laser pulse hits the canopy first and causes three distinct echo pulses. A fraction of the laser pulse also hits the ground giving rise to another echo pulse. In situation 2, the laser beam is reflected from a flat surface at a small angle of incidence yielding an extended echo pulse width. In situation 3, the pulse is simply reflected by a flat surface at perpendicular incidence resulting in one single echo pulse with a shape identical to the transmitted laser pulse.

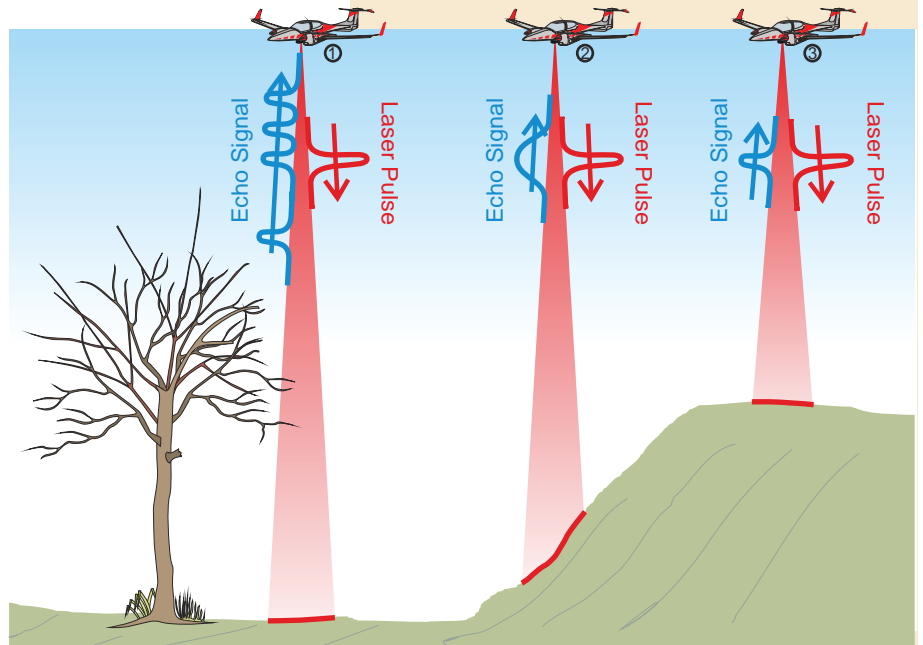

Fig. 1 Echo signals resulting from different types of targets

Echo Digitization of the *RIEGL* LMS-Q680i

The upper line of the acquisition diagram shows the analog signals: the first (red) pulse relates to a fraction of the laser transmitter pulse, and the next 3 (blue) pulses correspond to the reflections by the branches of the tree; the last pulse corresponds to the ground reflection.

This analog echo signal is sampled at constant time intervals (middle line) and is, in the following, analog-to-digital converted, resulting in a digital data stream (bottom line of the acquisition section). This data stream is stored in the *RIEGL* Data Recorder for subsequent off-line post processing, where the echo signals can be perfectly reconstructed and analyzed in detail to precisely derive target distance, pulse shape as an indicator for target type, and other parameters.

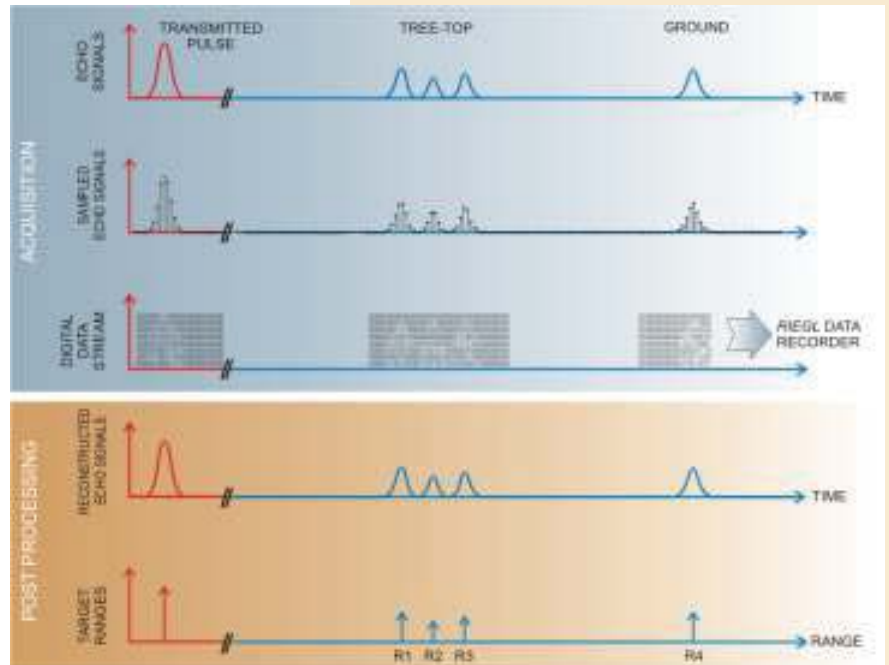

Fig. 2 Data acquisition and post processing

Based upon *RIEGL*'s long-standing expertise and experience in designing, manufacturing and marketing digitizing laser rangefinders for challenging industrial and surveying applications, and due to the careful design of the analog and digital front-end electronics, the LMS-Q680i records the complete information of the echo signal over a wide dynamic range. Thus, in post-processing the signal can be perfectly reconstructed and analyzed in detail to precisely derive target distance, target type, and other parameters.

Multiple-time-around Data Acquisition and Processing

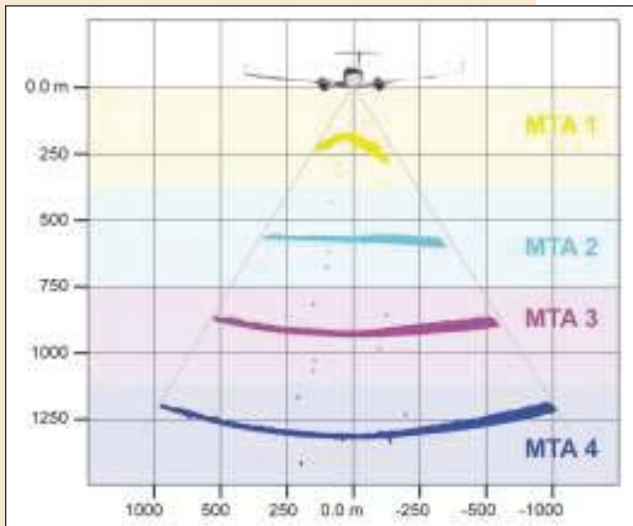

Fig. 3 Profile of scan data processed in MTA zones 1 to 4

In time-of-flight laser ranging a maximum unambiguous measurement range exists which is defined by the measurement repetition rate and the speed of light. When scanning at a pulse repetition rate of, e.g., 400 kHz, measurement ranges above approx. 375 m are ambiguous caused by an effect known as "Multiple-time-around" (MTA). In such case target echoes received may not be associated with their preceding laser pulses emitted any longer (MTA-zone 1), but have to be associated with their last but one (MTA-zone 2), or even last but two laser pulses emitted (MTA-zone 3), in order to determine the true measurement range.

Figure 3 gives an impression of ALS data where each single echo of a scan line is associated with each of its last four preceding laser shots emitted. Each single echo is represented by a measurement range calculated in MTA zone 1, 2, 3 and 4 respectively, but only one of the

four realizations represents the true point cloud model of the scanned earth surface. The chosen example shows scan data correctly allocated in MTA zone 2, where the earth surface appears more or less flat in contrast to the typical spatial characteristics of incorrectly calculated ambiguous ranges in MTA zones 1, 3 and 4.

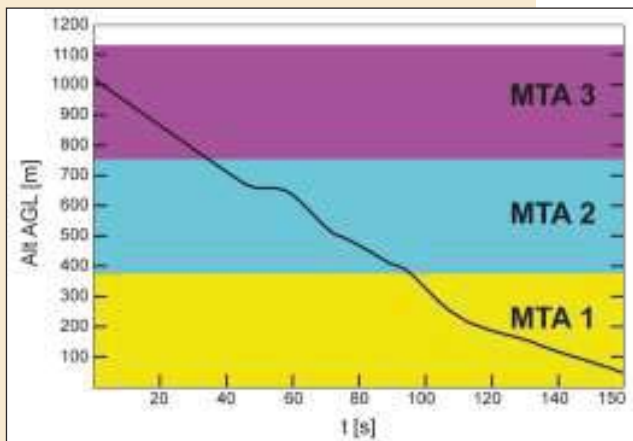
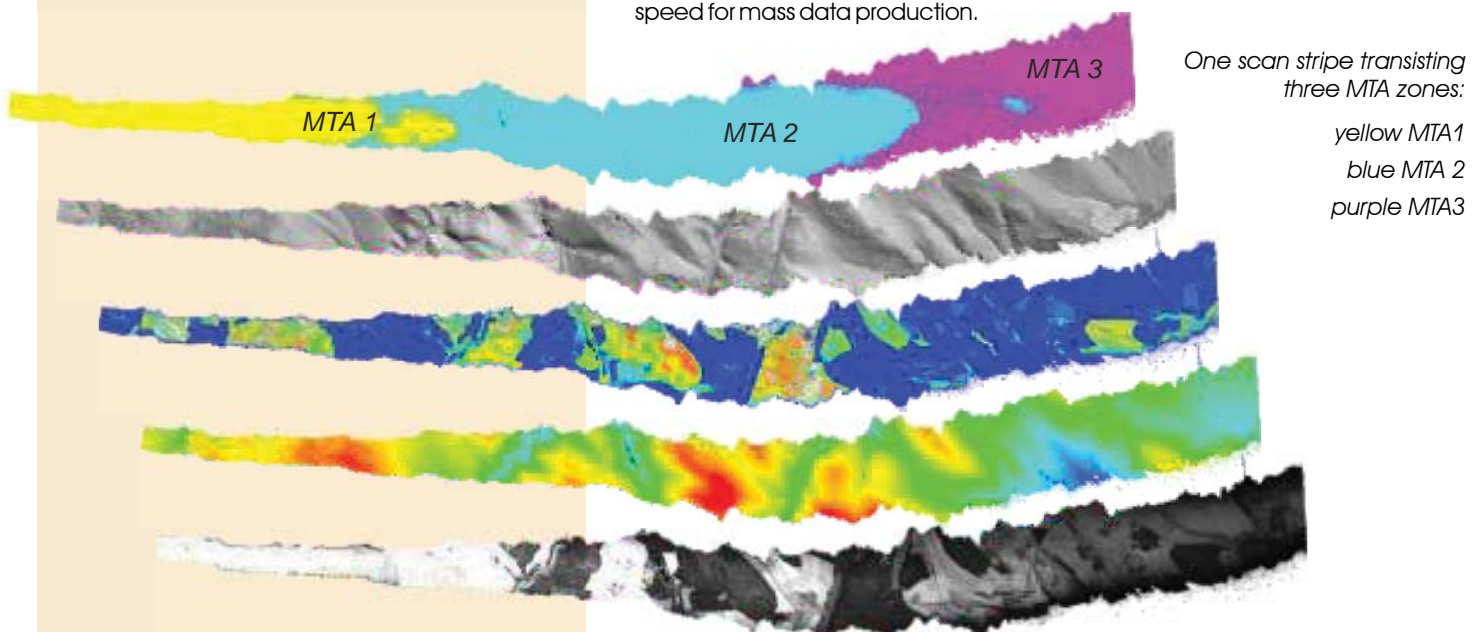

Fig. 4 Flight altitude above ground level descending from 1,000 m to 240 m within 150 seconds

The RIEGL LMS-Q680i is capable of acquiring echo signals which arrive after a delay of more than one pulse repetition interval, thus allowing range measurements beyond the maximum unambiguous measurement range. Unique techniques in high-speed signal processing and a novel modulation scheme applied to the train of emitted laser pulses permit range measurements without any gaps at any distance within the instrument's maximum measurement range. The specific modulation scheme applied to the train of emitted laser pulses avoids a total loss of data at the transitions between MTA-zones and retains range measurement at approximately half the point density.

The correct resolution of ambiguous echo ranges is accomplished using RIANALYZE in combination with the associated algorithm library RIMTA, which does not require any further user interaction, and maintains fast processing speed for mass data production.



Maximum Measurement Range & Point Density for RIEGL LMS-Q680i

PRR = 400 kHz

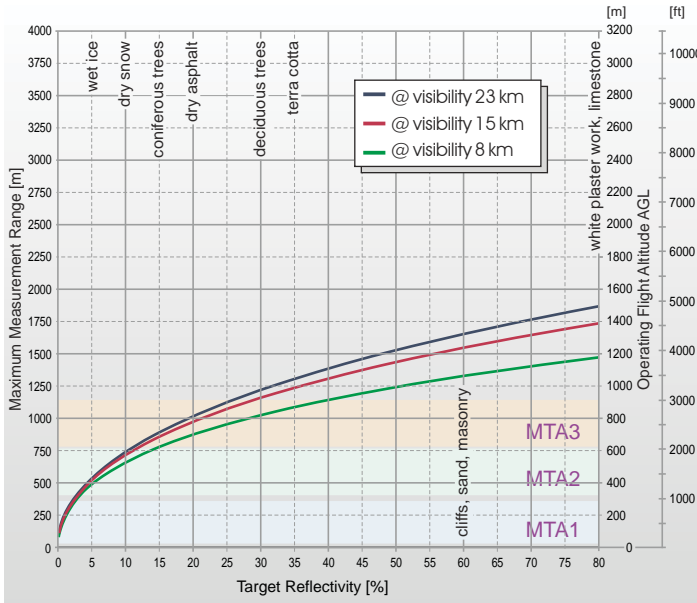

PRR = 400 kHz

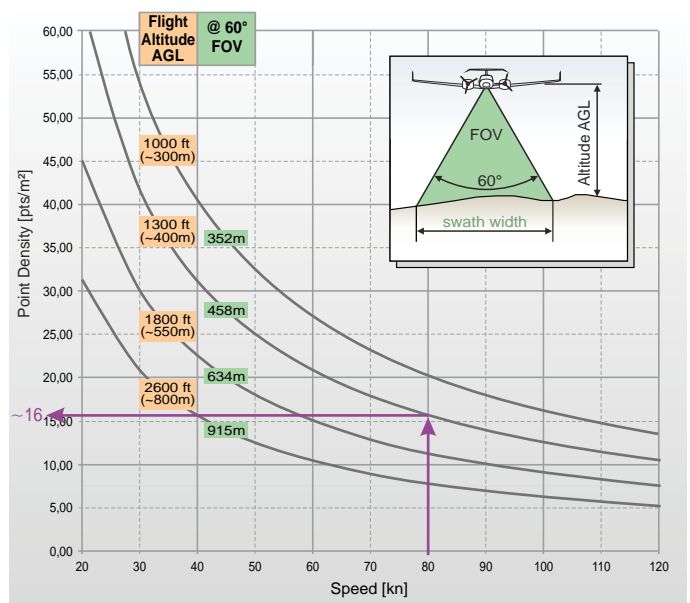

Example: Q680i at 400,000 pulses/second
Altitude = 1300ft AGL, Speed = 80 kn
Resulting Point Density ~ 16 pts/m²

PRR = 300 kHz

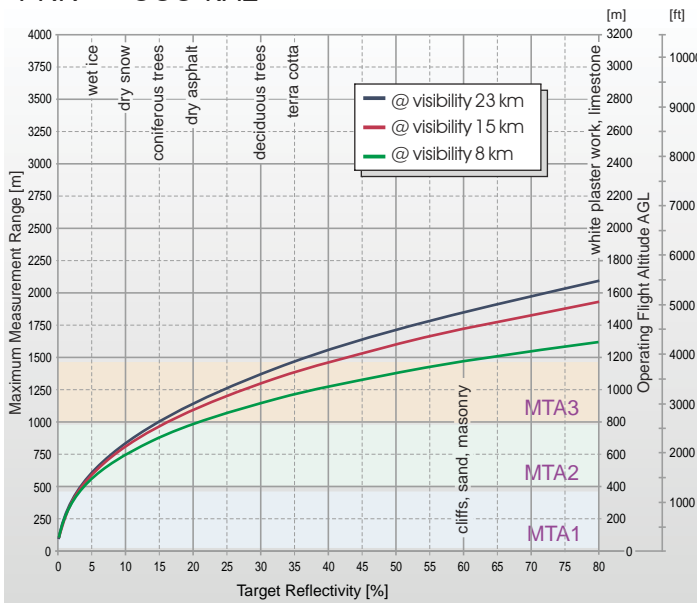

PRR = 300 kHz

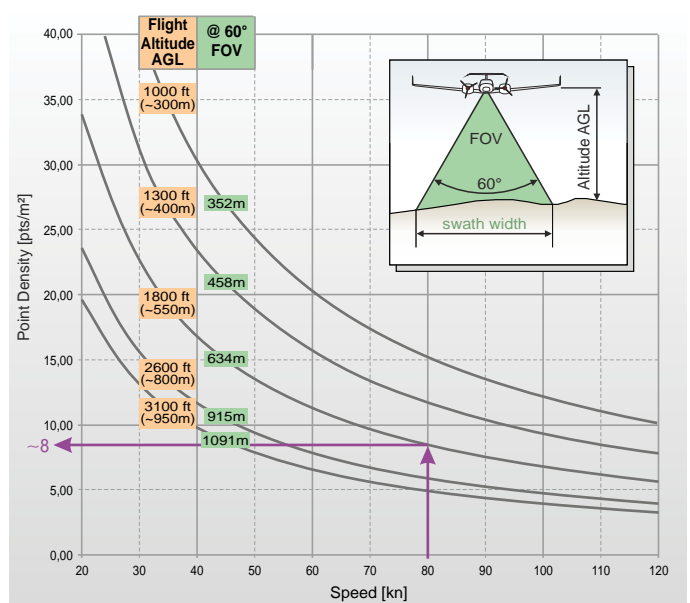

Example: Q680i at 300,000 pulses/second
Altitude = 1800ft AGL, Speed = 80 kn
Resulting Point Density ~ 8 pts/m²

**The following conditions are assumed:
for the Operating Flight Altitude AGL**

- ambiguity resolved by multiple-time-around (MTA) processing & flight planning
- target size ≥ laser footprint
- scan angle 60°
- average ambient brightness
- roll angle +/-5°

for MTA zones

- MTA1: no ambiguity / 1 pulse „in the air“
- MTA2: 2 pulses „in the air“
- MTA3: 3 pulses „in the air“

- half the point density in MTA-transition zones
- width of transition between MTA-zone 1 and 2 approx. 45 m
- width of transition between MTA-zone 2 and 3 approx. 75 m

Maximum Measurement Range & Point Density for RIEGL LMS-Q680i

PRR = 200 kHz

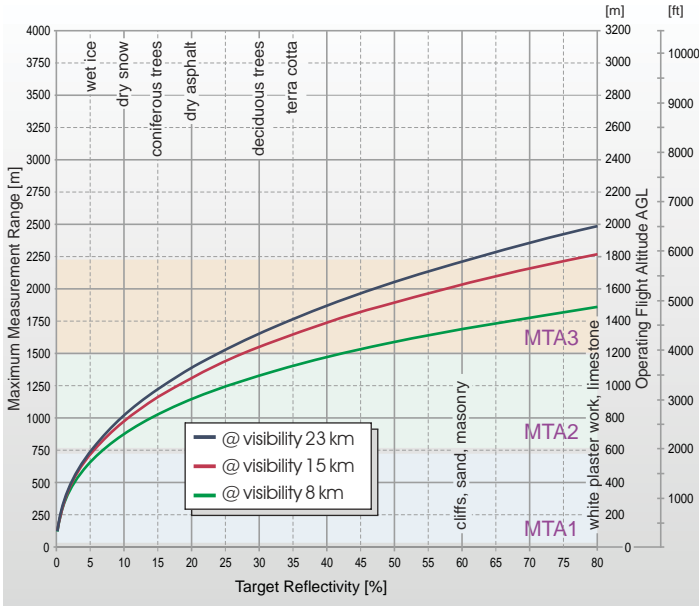

PRR = 200 kHz

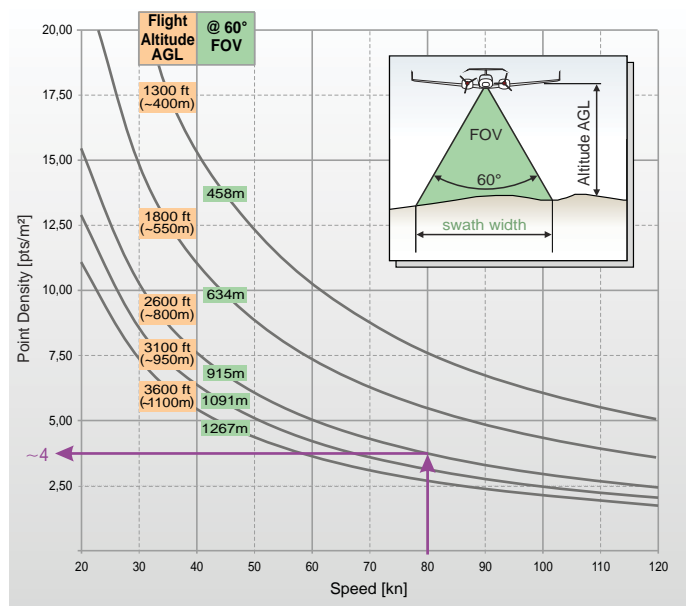

Example: Q680i at 200,000 pulses/second
Altitude = 2600ft AGL, Speed = 80 kn
Resulting Point Density ~ 4 pts/m²

PRR = 80 kHz

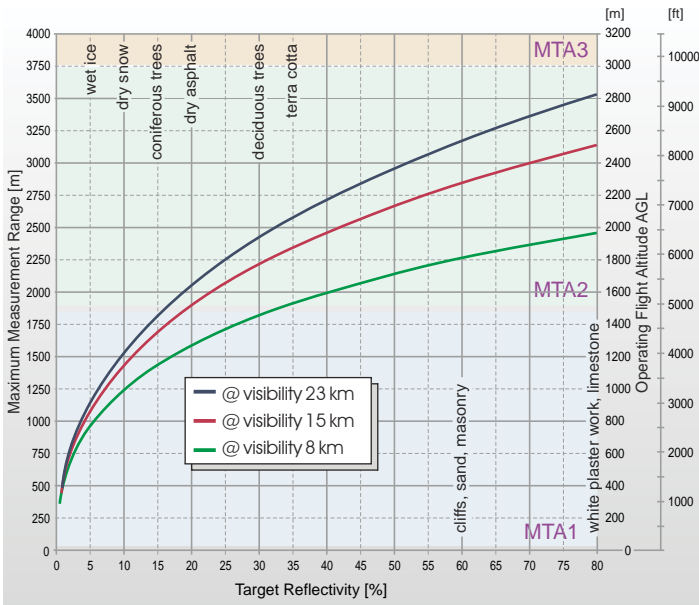

PRR = 80 kHz

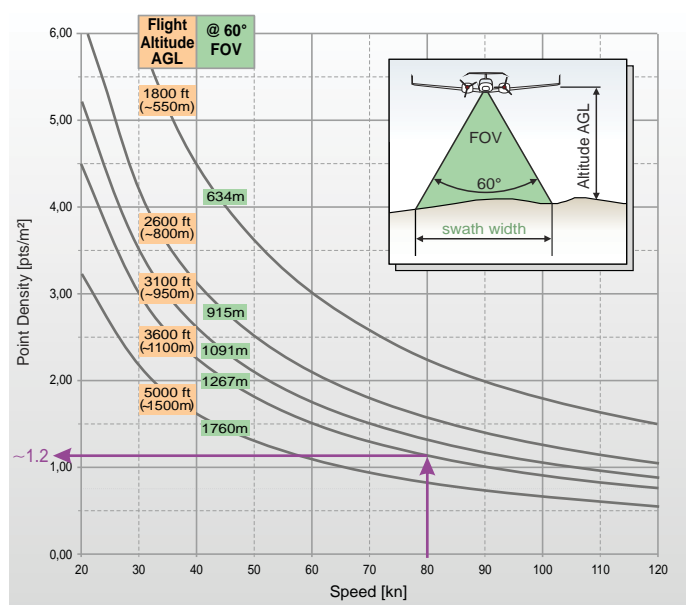

Example: Q680i at 80,000 pulses/second
Altitude = 3600ft AGL, Speed = 80 kn
Resulting Point Density ~ 1.2 pts/m²

**The following conditions are assumed:
for the Operating Flight Altitude AGL**

- ambiguity resolved by multiple-time-around (MTA) processing & flight planning
- target size ≥ laser footprint
- scan angle 60°
- average ambient brightness
- roll angle +/-5°

for MTA zones

- MTA1: no ambiguity / 1 pulse „in the air“
- MTA2: 2 pulses „in the air“
- MTA3: 3 pulses „in the air“

- half the point density in MTA-transition zones
- width of transition between MTA-zone 1 and 2 approx. 45 m
- width of transition between MTA-zone 2 and 3 approx. 75 m

☉ origin of scanner's local coordinate system

bottom view

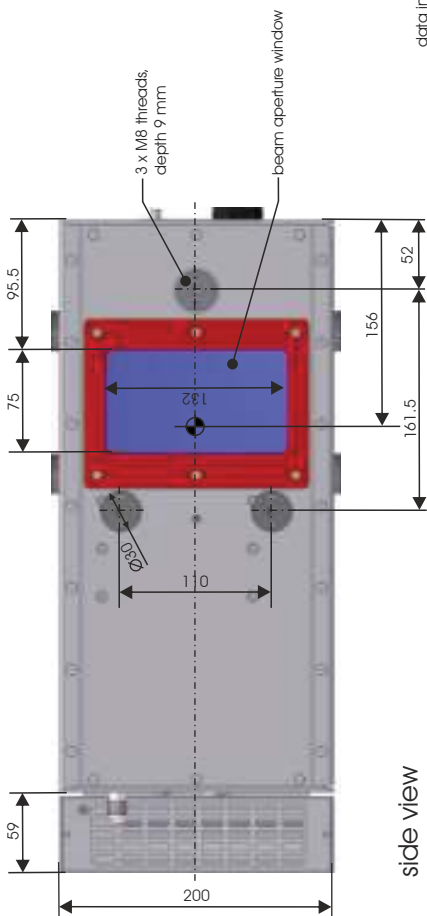

side view

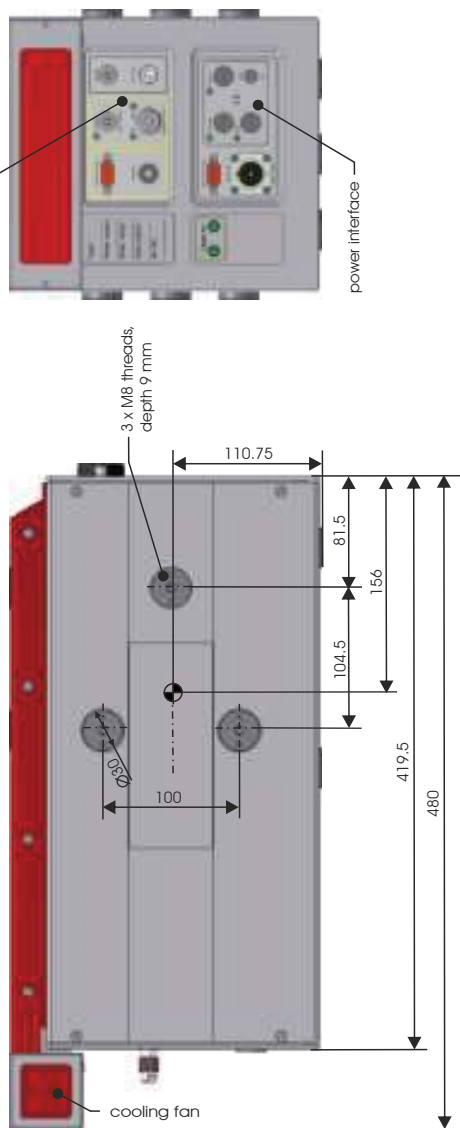

rear view

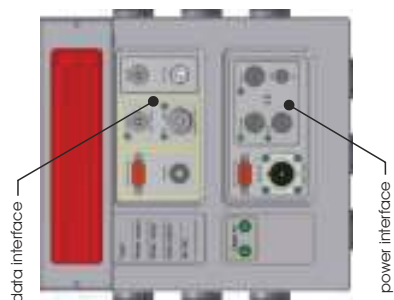

front view

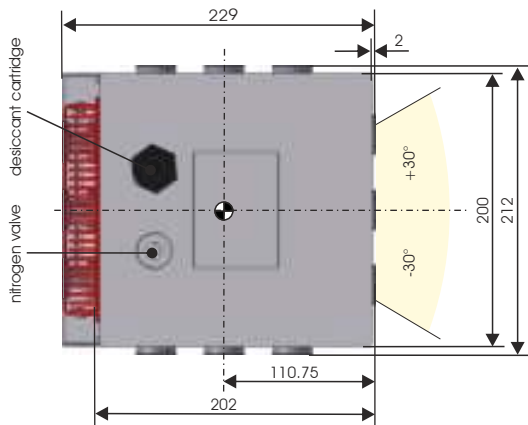

top view

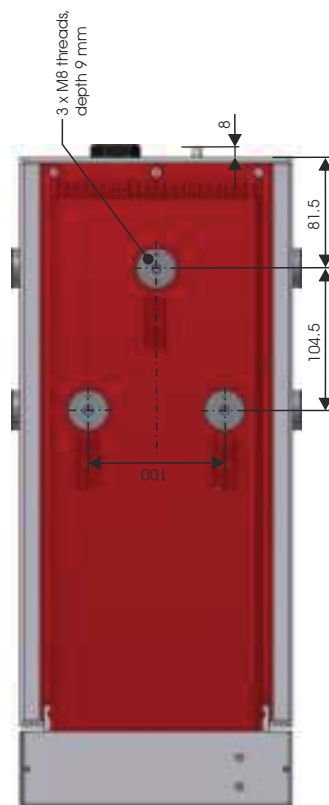

all dimensions in mm



RIEGL[®]
LASER MEASUREMENT SYSTEMS

RIEGL Laser Measurement Systems GmbH, 3580 Horn, Austria
Tel.: +43-2982-4211, Fax: +43-2982-4210, E-mail: office@riegl.co.at

RIEGL USA Inc., Orlando, Florida 32819, USA
Tel.: +1-407-248-9927, Fax: +1-407-248-2636, E-mail: info@rieglusa.com

RIEGL Japan Ltd., Tokyo 1640013, Japan
Tel.: +81-3-3382-7340, Fax: +81-3-3382-5843, E-mail: info@riegl-japan.co.jp

www.riegl.com